



**SCRATCHBUILDING A 1/32 SCALE  
F4F WILDCAT COCKPIT  
BY  
MIKE ASHEY**

This article presents detailed, step by step techniques on scratchbuilding a cockpit as well as some other interior parts. For this project I picked Revell's 1/32 scale F4F wildcat. This kit has a very good external shape and it is a good representation of a Wildcat. The kits cockpit is sparse on details although the shapes of the interior parts is pretty good. I used lots of pictures and drawings to capture the shapes of the interior parts, the relative size of each part, the surface details and their locations relative to one another and the inside the cockpit.

I like to use both Evergreen and Plastruct shapes, strips and sheet plastic and rod for scratchbuilding and I use super glue for all my gluing needs. I used Waldron instruments for the console and Model Technologies photoetch seat belt hardware. Where appropriate I used kit parts such as the control stick.

The art of scratchbuilding has been greatly diminished over the past decade due to resin and photoetch detail sets as well as newer aircraft kits that have better detailed cockpits. However for those who still want to learn how to scratchbuild, the articles and books that I have written will help you dive into and advance your scratchbuilding skills.

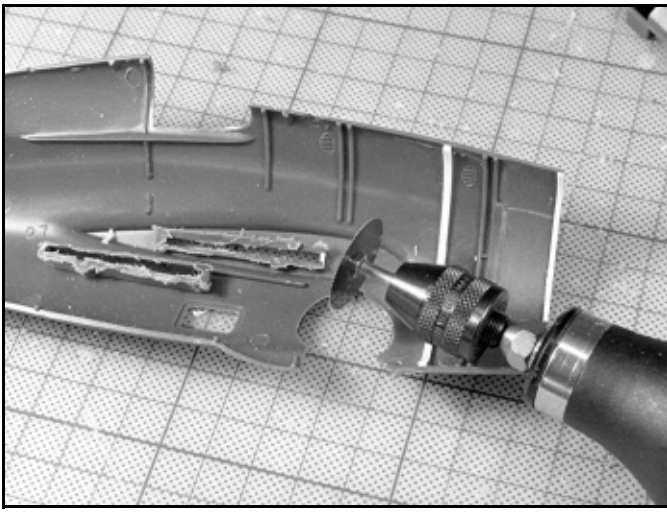

The first of many steps was to remove the interior protrusions that I thought would interfere with the new interior parts.

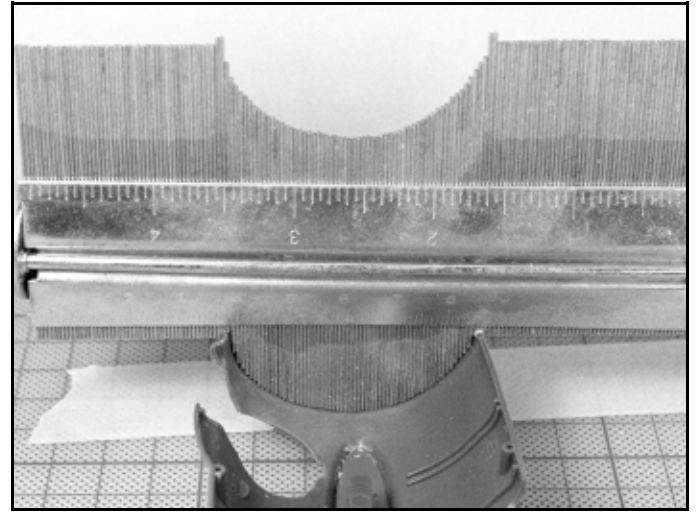

I drew lines where I wanted to add interior framing. I used a contour gage to create a cross section of one side of the fuselage where I drew the lines.

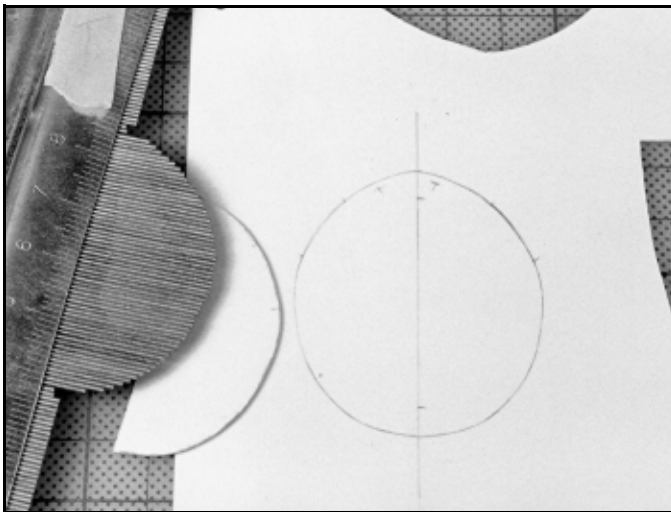

I made a template from the cross section and then traced it onto plastic sheet, duplicating both sides.

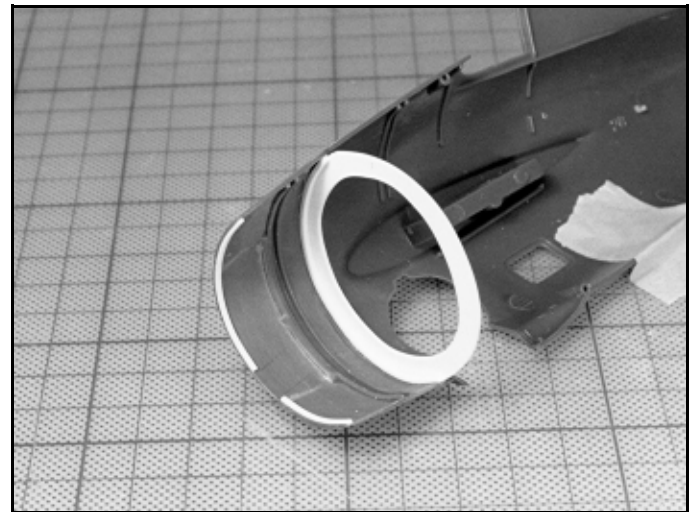

I glued small strips of plastic along the lines that I drew on the inside areas so that the interior framing would have a positive seating. I cut out the interior area of the new part to make a ring and glued it into place.

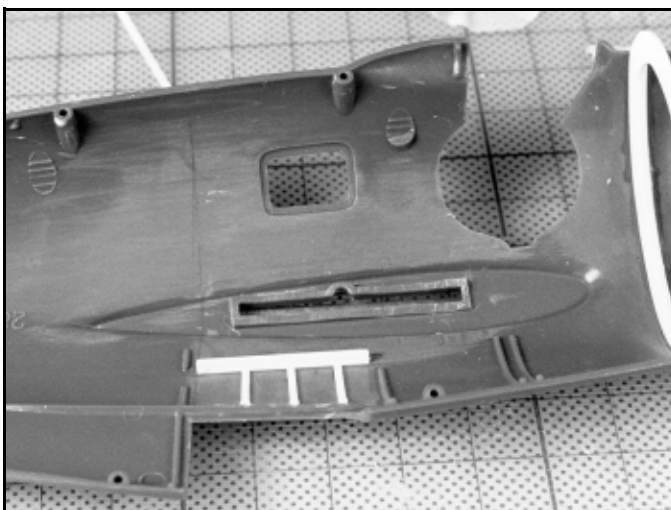

Next I drew framing for the cockpit and then glued strips along the pencil lines.

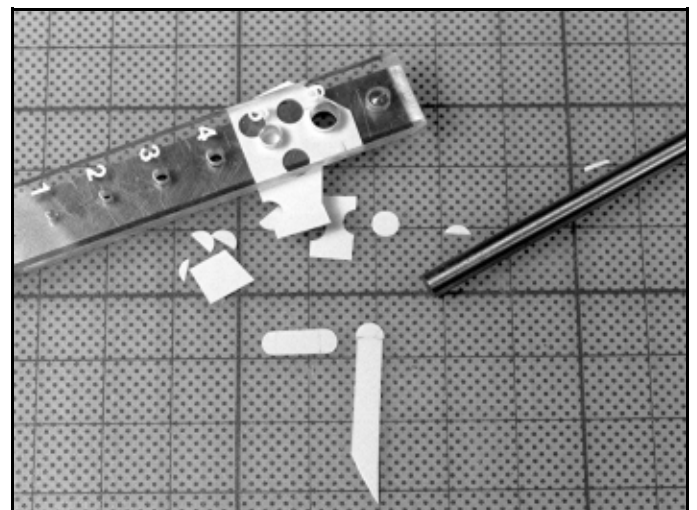

Next I started making mechanical details for the landing gear wall. I made disks from my Waldron punch, cut them in half and then glued them to straight lengths.

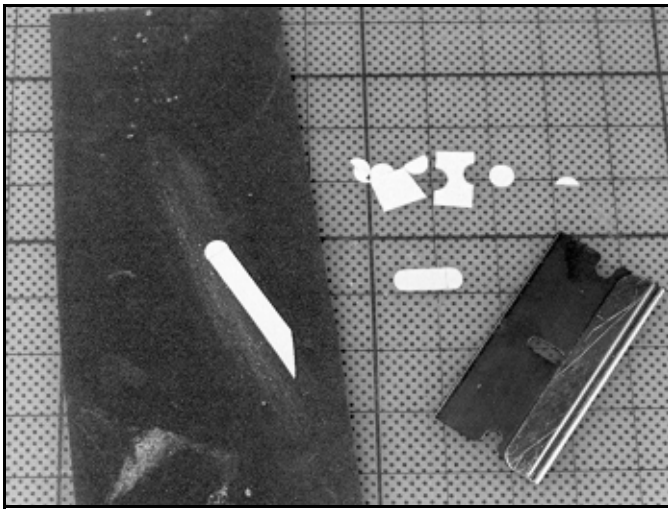

I added beads of super glue along the seam lines and then ran them across fine grit sandpaper to smooth out the glue.

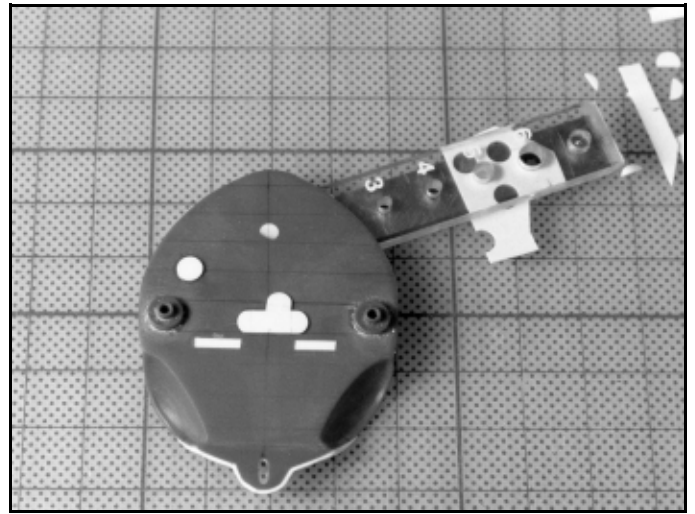

I decided to use the kit part so I sanded off all the detail, drew lines and then started adding new details. I also added some plastic strips to the bottom of the part to close up a gap with the interior area of the fuselage.

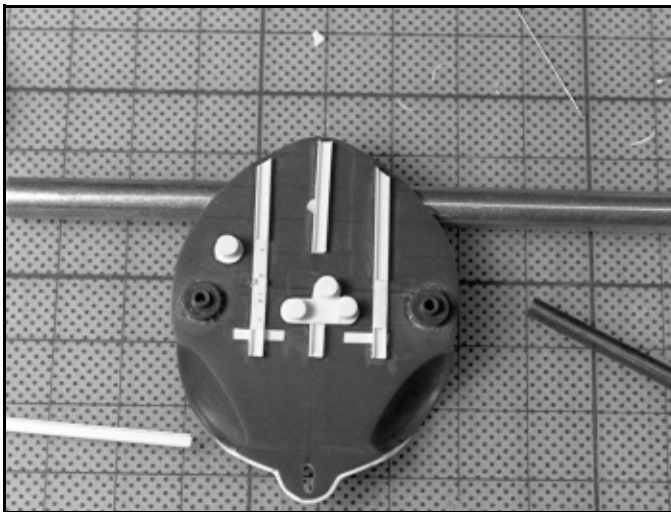

I made chain pulleys from various sizes of punched out disks that were glued together. The channel framing came from Evergreen and Plastruct pre-shaped parts.

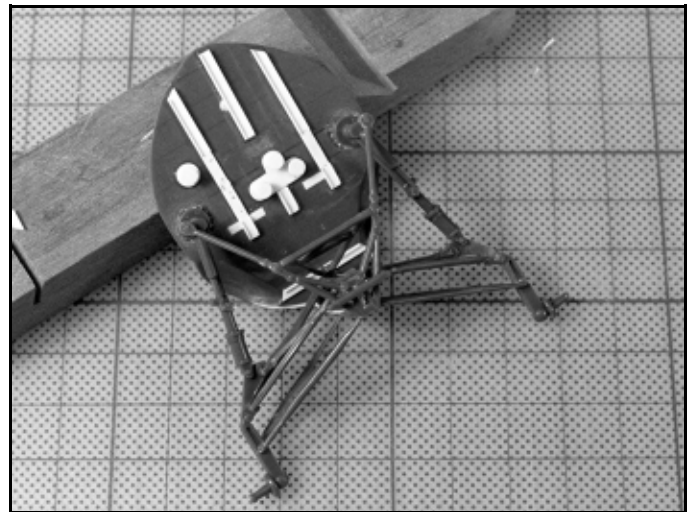

I assembled the landing gear and checked the fit to be sure none of the new details interfered with the kit parts.

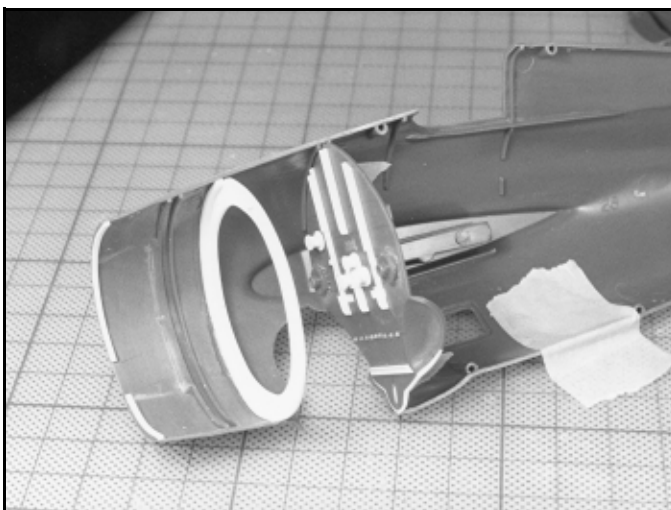

The new landing gear wall gets a fit check to be sure there are no more gaps between the wall and the interior areas of the fuselage.

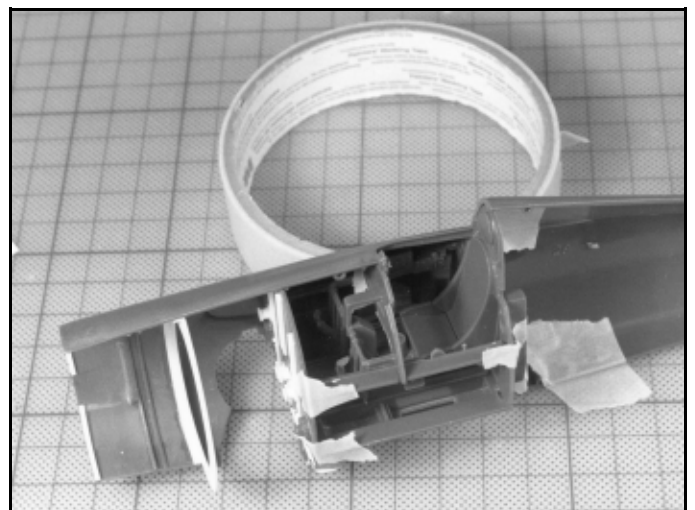

I taped together the cockpit to mark the locations of various interior parts on both sides of the fuselage walls so that I would have some reference points for scratchbuilding.

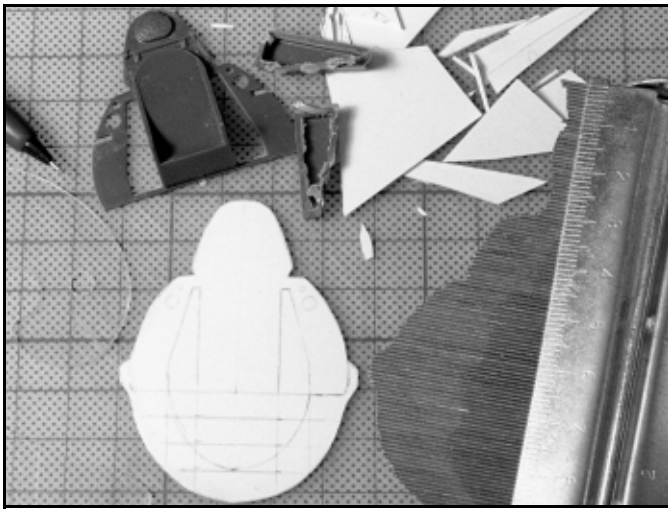

I used the kit's rear wall and a contour gage to make a new wall. I then drew in the areas where plastic needed to be removed.

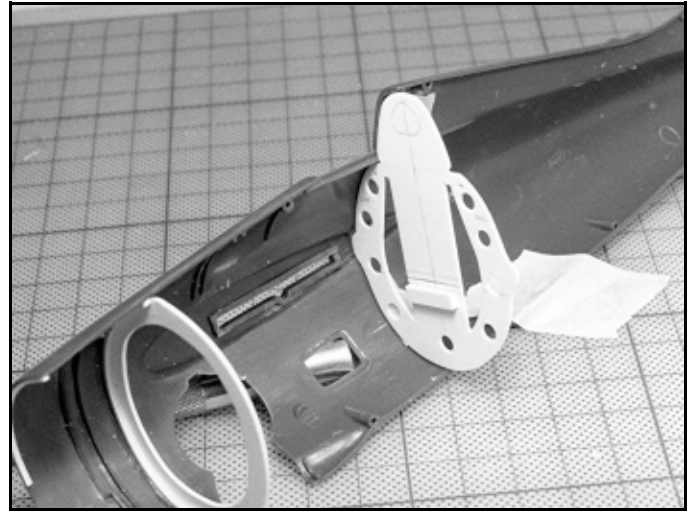

Every interior part has to get a fit check to be sure there are no problems with the shape of the part. I also close up the fuselage so that both sides can be checked.

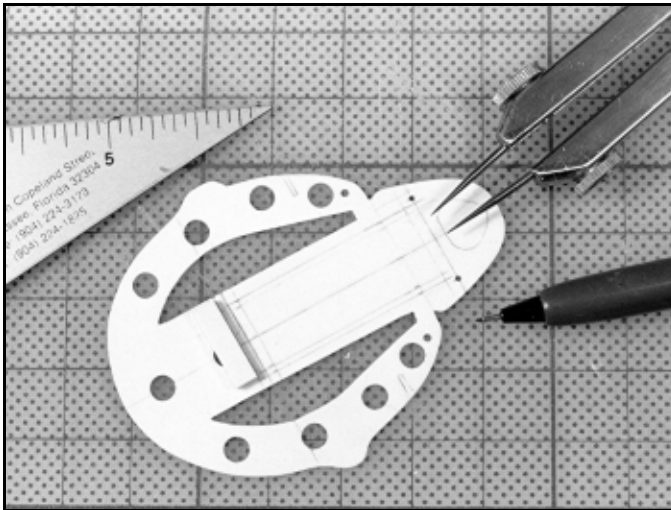

I added a ledge for the floor and then drew in more details that will be added.

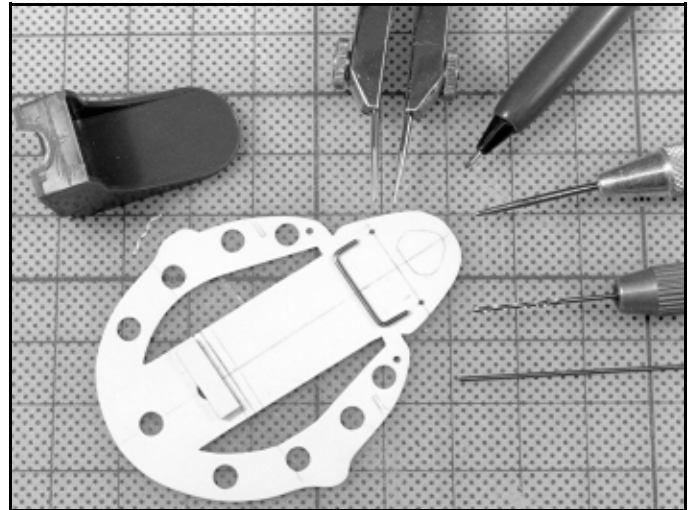

I used stiff brass wire for the seat frame detail. I used the kits seat to help locate where the holes should be drilled for the frame.

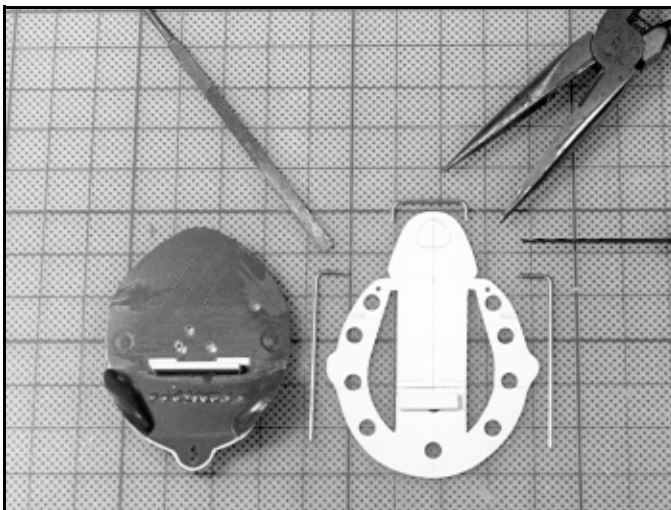

The three seat frame parts are complete and they have received their final fit check.

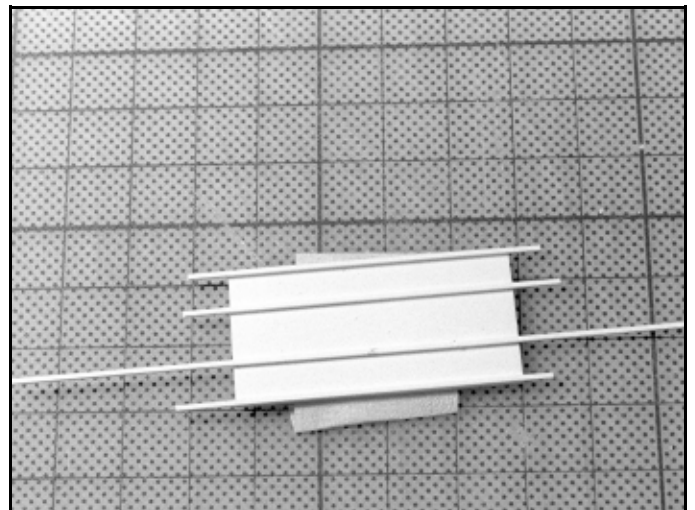

The floor length was measured and cut out from sheet plastic. Lines were drawn for the floor framing and then stripes of plastic were super glued into place.

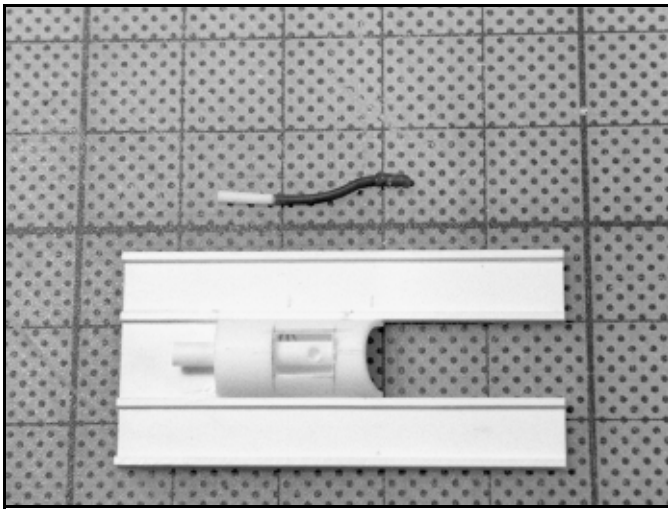

The control stick cover was made by cutting a length of rod in half, shaping the end and cutting out a box shape for the control stick. I also cut out the center area of the floor and I glued plastic rod to the kits control stick to make it longer.

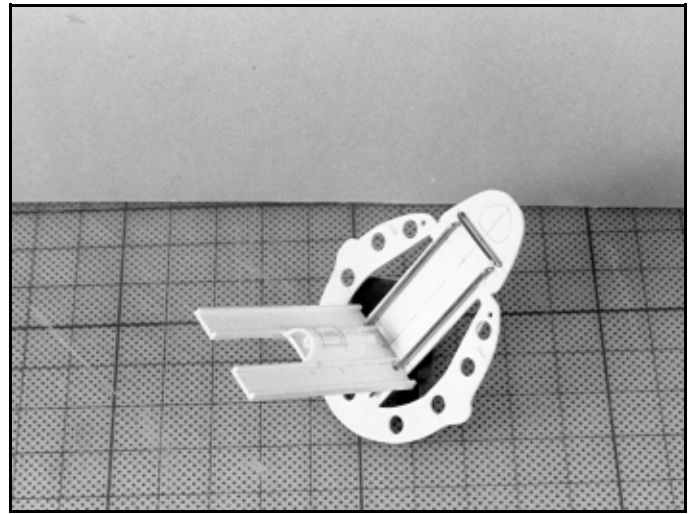

The seat framing and the floor were then glued to the cockpit rear wall.

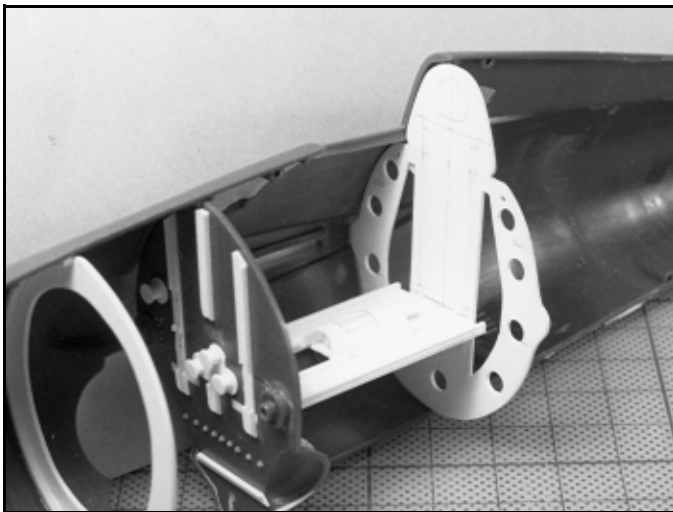

The landing gear wall and the rear cockpit wall are getting fit checks to be sure everything fits together.



I drew the side view of the seat onto .020 inch sheet plastic.

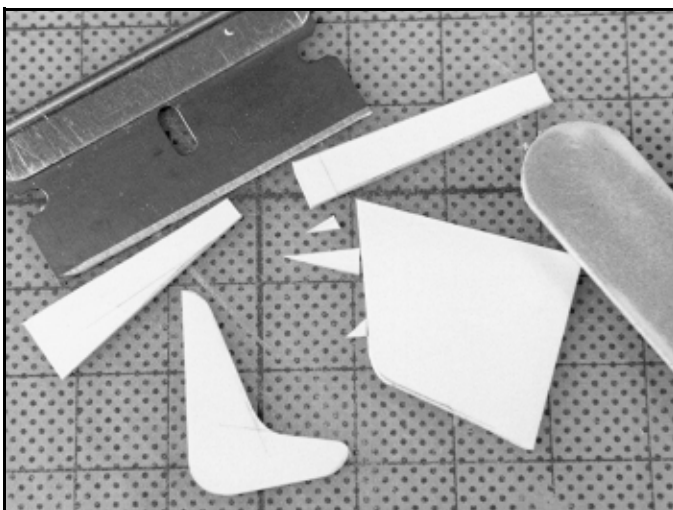

The part was cut out and shaped with sanding sticks.

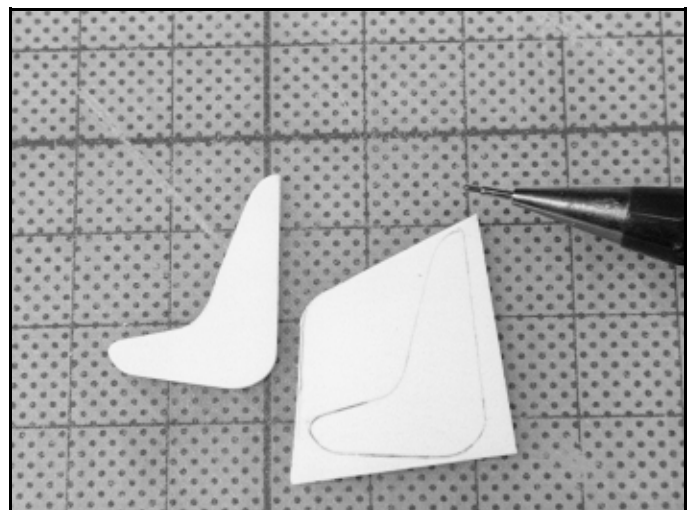

Once I was satisfied with the shape I traced it onto another section of sheet plastic. The second part was cut out and shaped. Both parts were then white glued together and shaped so that they were duplicated.

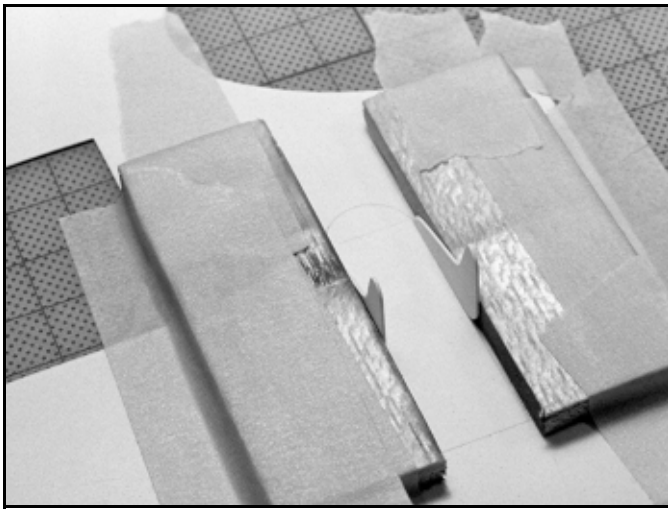

I soaked the side parts to dissolve the white glue. I drew the backing onto .010 inch plastic, used balsa strips to set the side locations and then glued the seat sides in place.

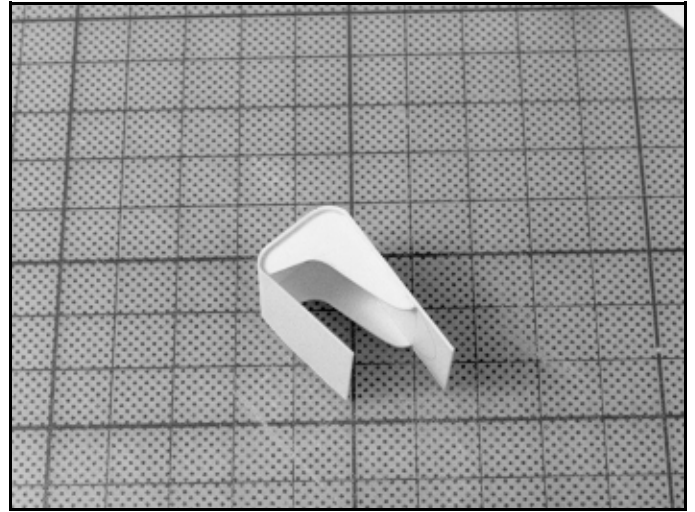

The plastic sheeting was then carefully bent into place and beads of super glue applied along the edges.

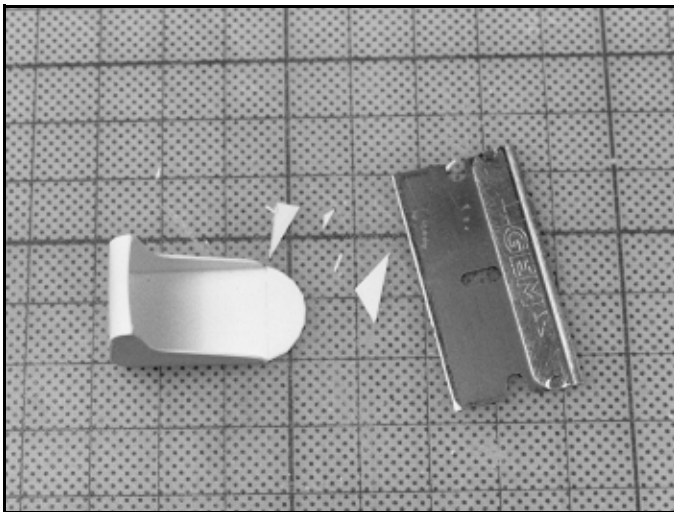

The sides, top and front were trimmed with a sharp single edge razor blade. I made small cuts along the circle to remove as much of the plastic as possible.

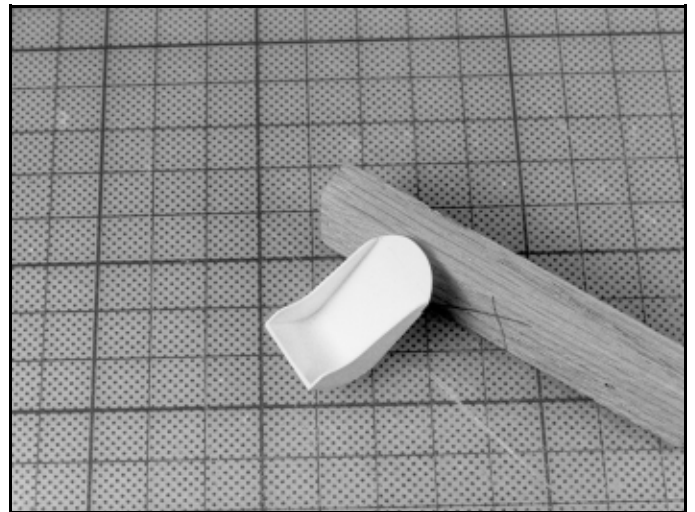

The top of the seat was shaped with a sanding stick and the sides smoothed by running the seat across a stationary piece of sandpaper.

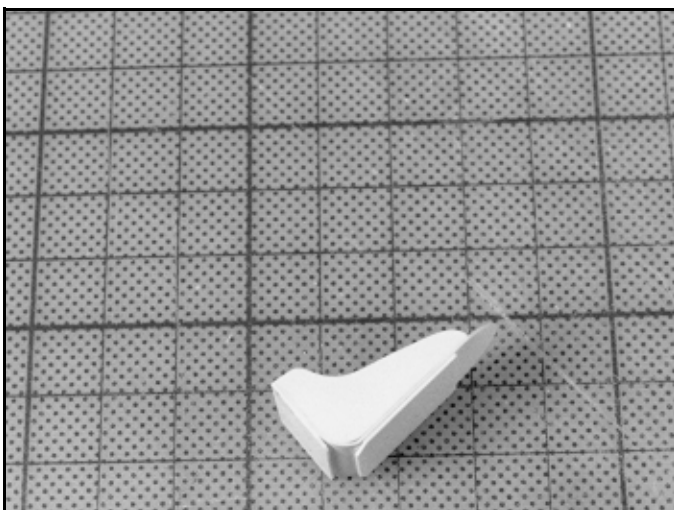

To add strength to the seat and to represent armor plating, I laminated sections of .020 inch sheet to the back and bottom.

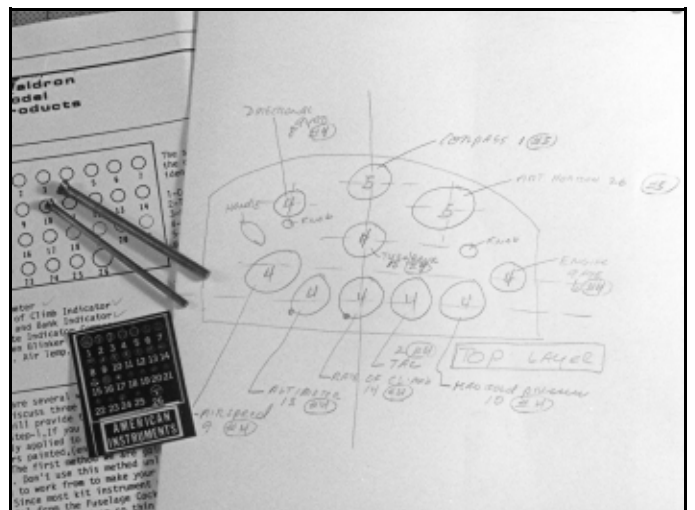

To scratchbuild the console I drew the console and made notes on where the individual instruments would go. I also noted what diameter punch tools would be needed for each instrument.

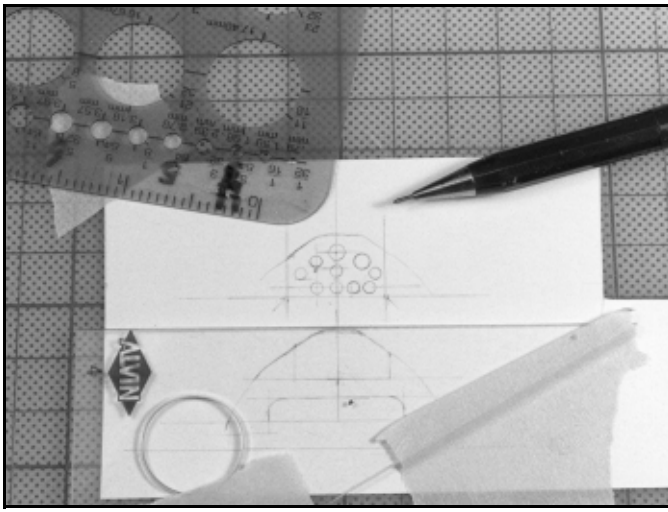

The top layer of the console was drawn with drafting triangles and circle templates.

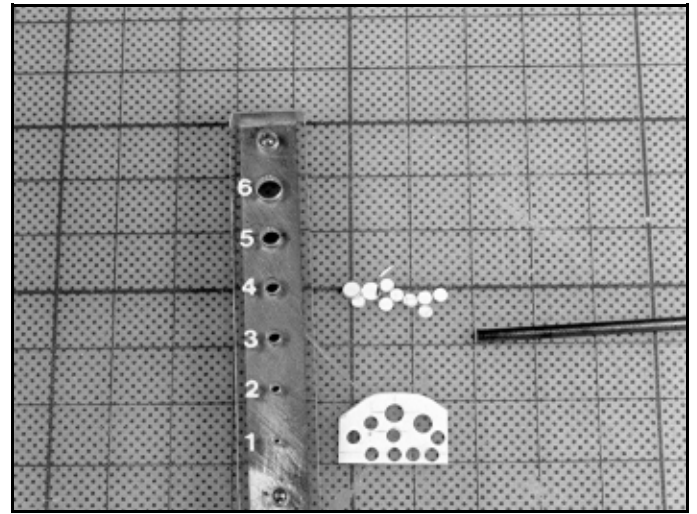

The part was cut out and I used various diameters of Waldron punches to make the instrument holes following the drawing that I made.

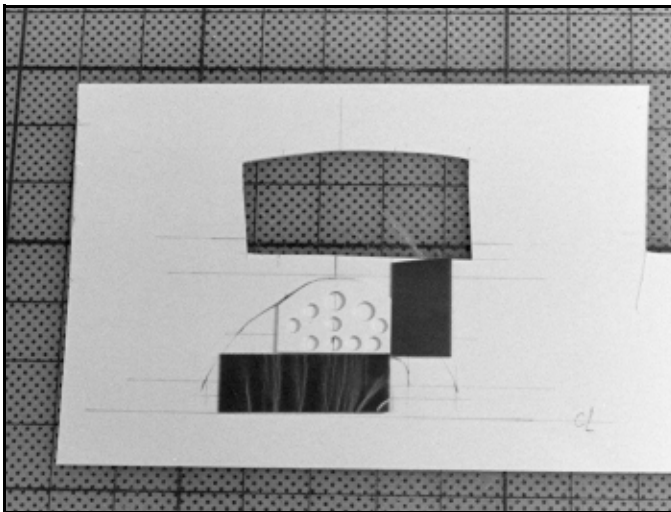

The lower level of the console was then drawn and I used the upper level to make sure the drawing had the correct dimensions.

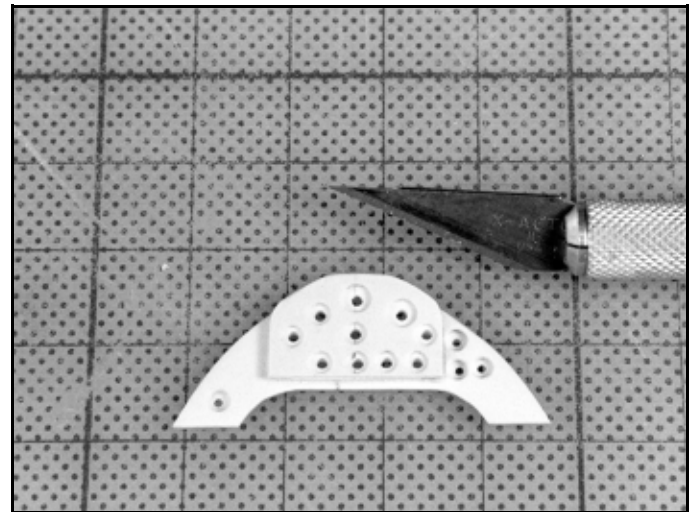

The new console is now complete. The instruments will be glued into place with white glue and the tiny holes will allow the glue to seep out the back.

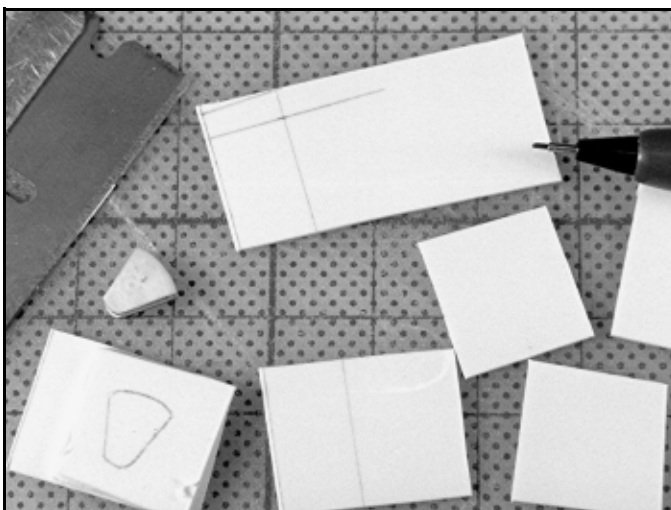

I glued several layers of plastic together and then traced the outlines of the throttle and mixture assemblies using the template that I made for scratchbuilding.

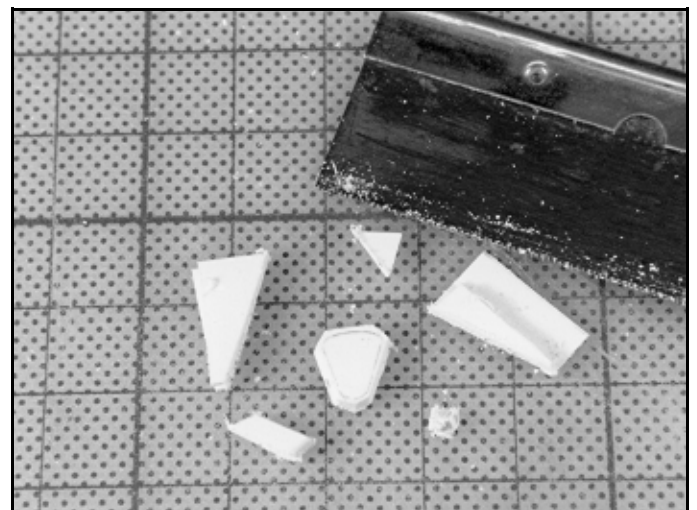

The parts were carefully cut out using a razor saw. The parts were then shaped with sanding stick. I placed parts in my micro vise and then cut channels into the tops for levers using the razor saw.

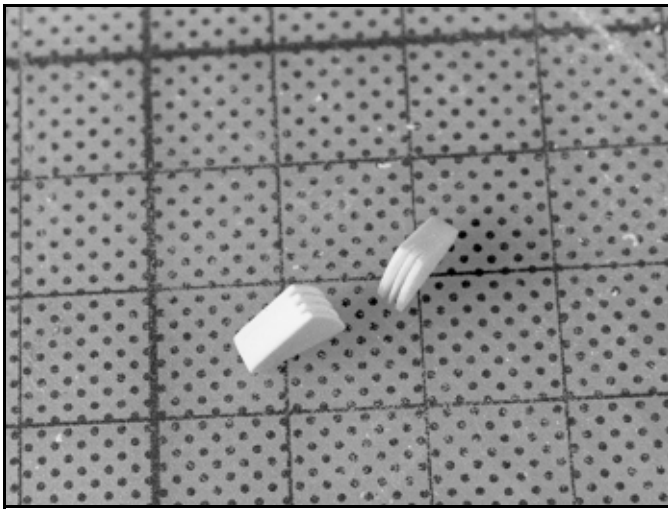

The two quadrants look pretty good.

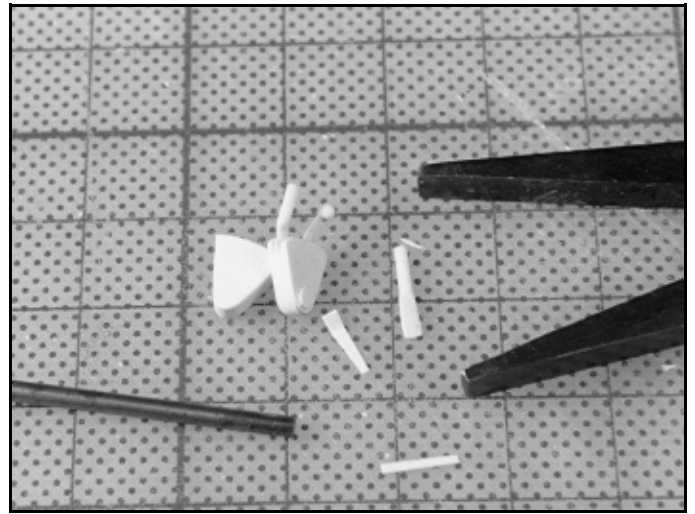

I made levers with small lengths of rod and flat stock. I used flat faced pliers to mash the round plastic along its length so that individual levers would have both a flat and round shape along their length.

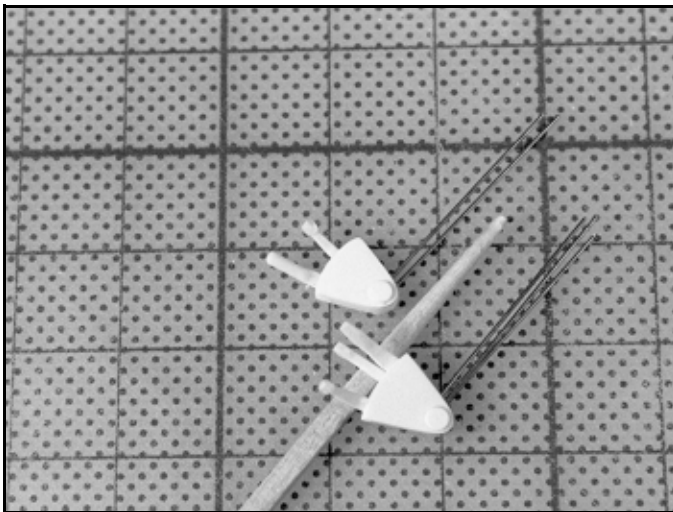

I drilled holes in the sides and added stiff brass wire to represent the control cables. The knobs and round disks were made from my Waldron Punch tool.

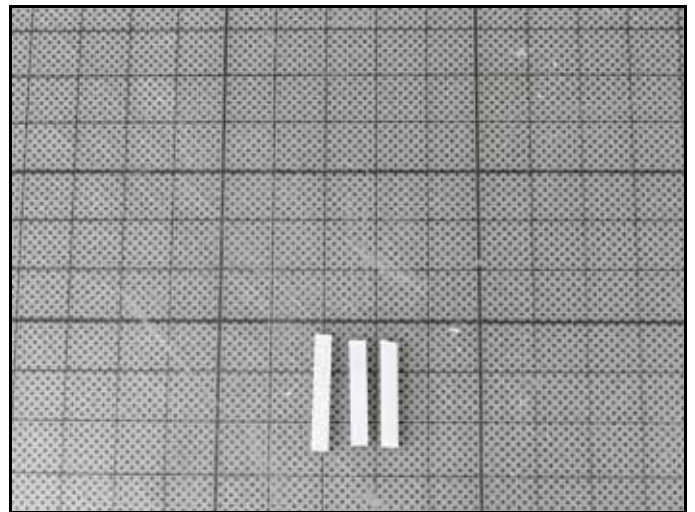

To make custom square and rectangle shapes I glue various thickness of plastic together to get the widths I need.

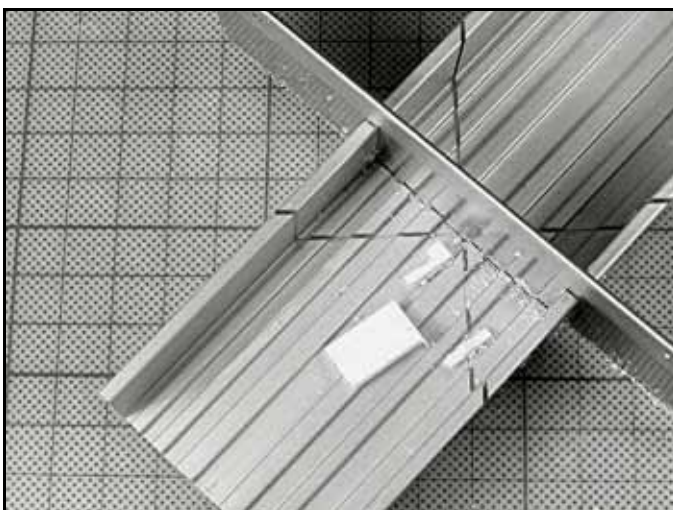

I used my razor saw and miter box to cut the parts into the lengths that I needed. I add beads of super glue to the seam lines and then smoothed the surfaces by running them across a stationary piece of sandpaper.

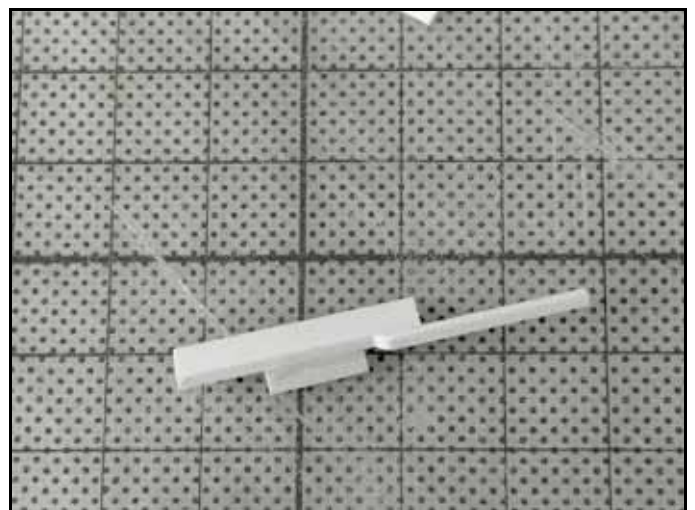

The side details are being assembled with various sizes and shapes of plastic.



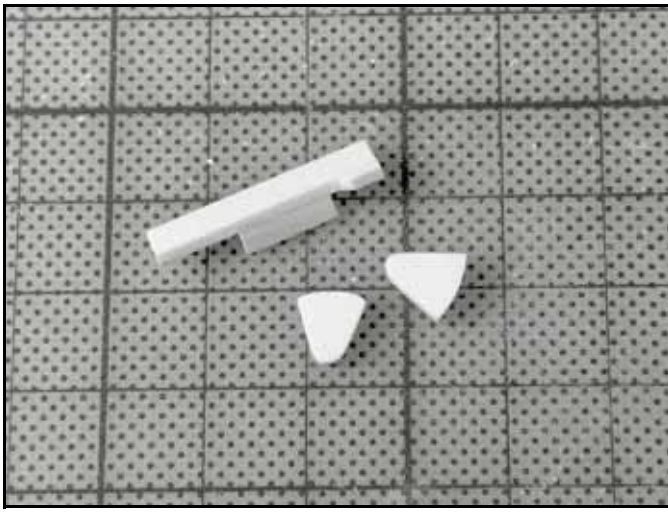

The left side cockpit parts are just about ready for their final fit checks and detailing.

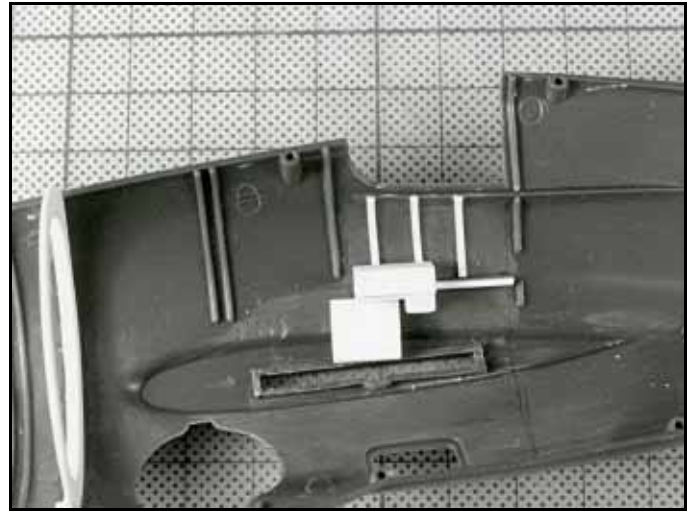

The right side electrical boxes have been assembled, cut and shaped and they are getting their final fit check.

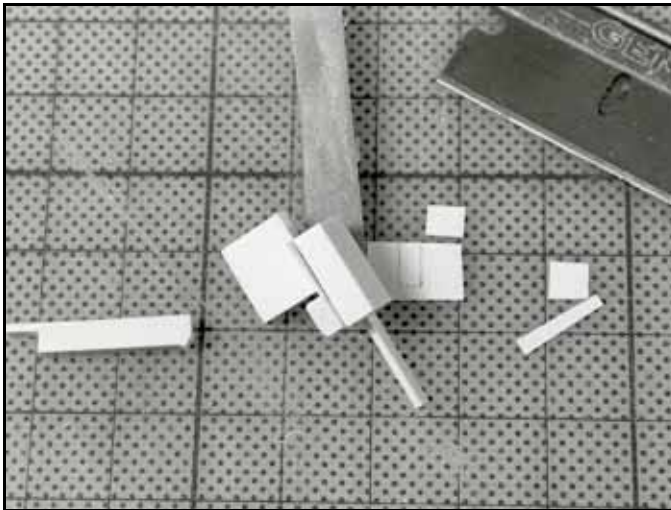

The electrical boxes for the right side are now getting additional details.

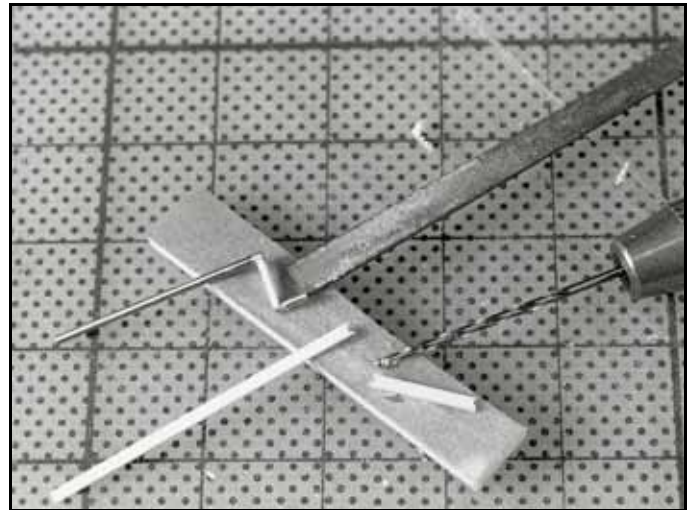

The crank for the landing gear was on the right side. To make the handle I drilled through strip stock and cut the plastic at the drill hole. This made a perfect cradle for the crank arm and handle which were made from stiff brass wire.



I used lengths of stiff brass wire for switches which I trimmed to length with electronics wire clippers. To keep the switch banks straight I drew lines on the boxes. Not a bad looking crank too!

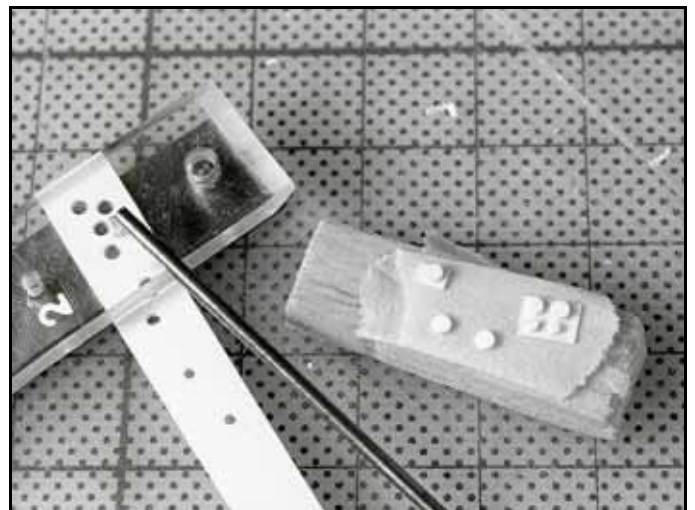

To make adjustment dials, I made various diameter disks with my Waldron Punch tool. Run the disks across fine grit sandpaper to remove any burrs.

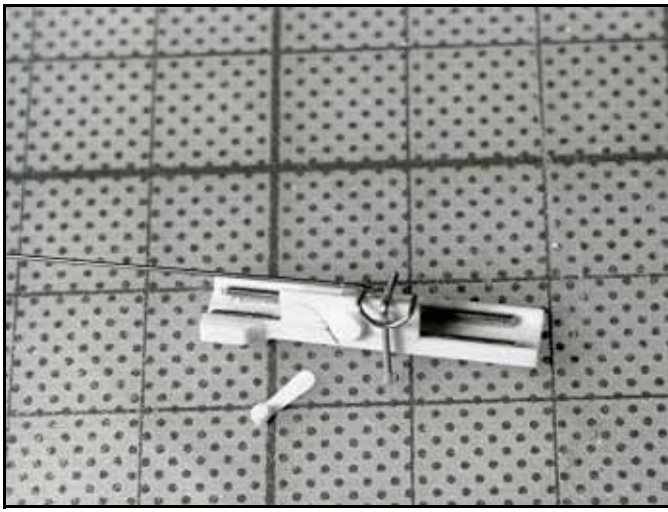

More details were added to the left side. The crank handle for the canopy was on the left side. I contoured a flat length of plastic and then added a punched out disk for the knob.

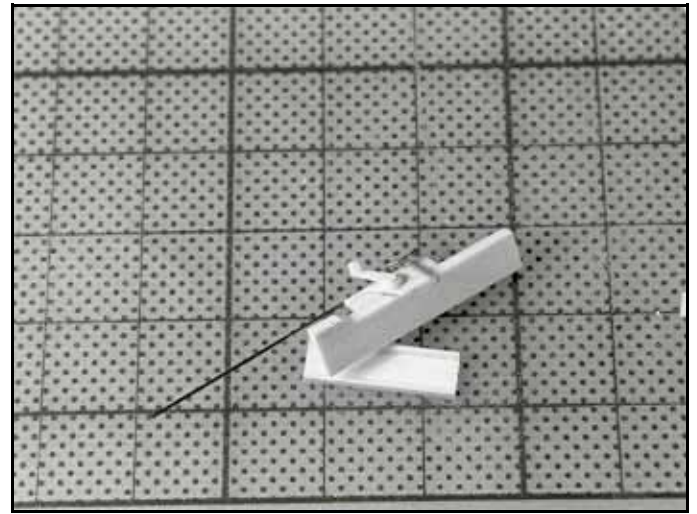

The left side parts are now complete and the adjustment dials were added after the parts were painted.



To contour the rudder pedals I ran the plastic parts across a large diameter wood dowel.



I cut out the kits rudder pedals from the frame and added my scratchbuilt ones. I also modified the part by making the rudder bar from brass wire.

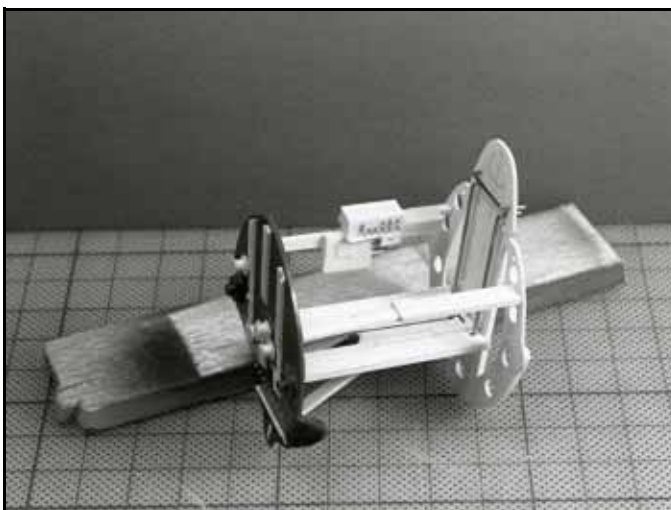

All the scratchbuilt parts are now getting their final fit checks.

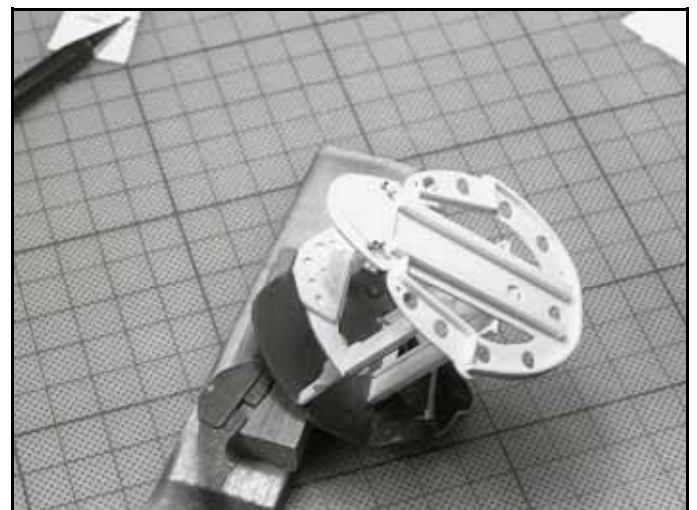

Even the console got several fit check to be sure the side parts did not interfere with the outer edges of the console.

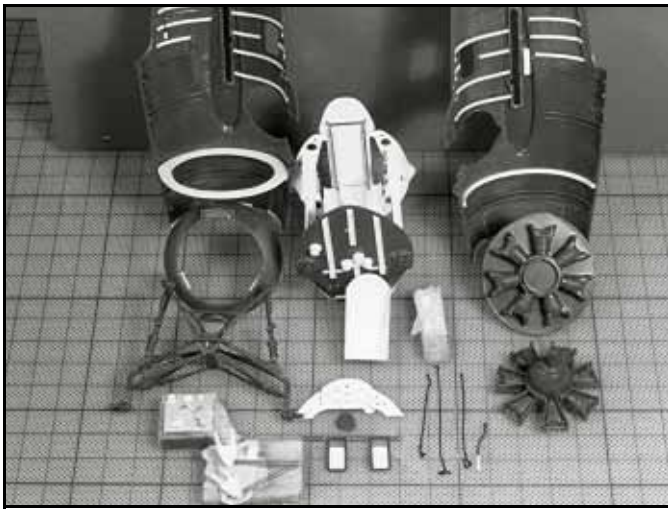

All the scratchbuilt parts are now ready for priming and painting.

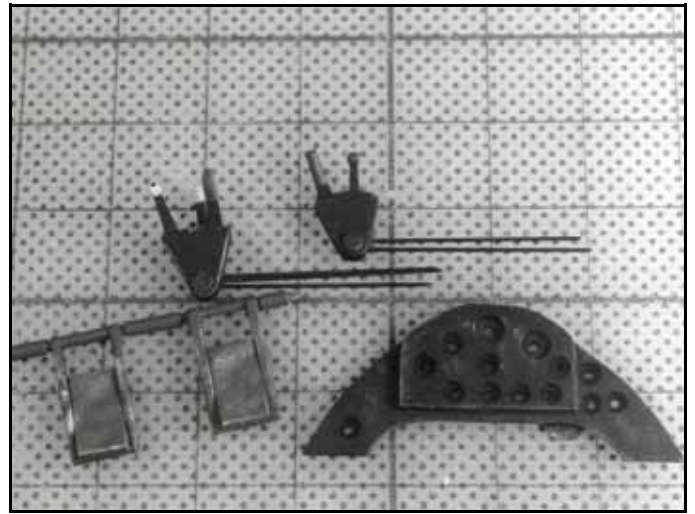

To enhance their appearance, I drybrushed Testors silver around the edges and in places that would show worn paint due to constant contact with the pilots hands or feet.

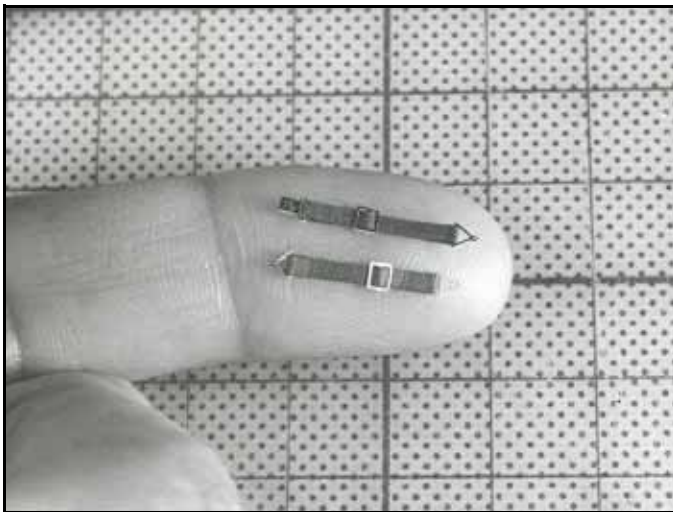

Masking tape painted light brown and Model Technologies photoetch belt hardware made great seat belts!

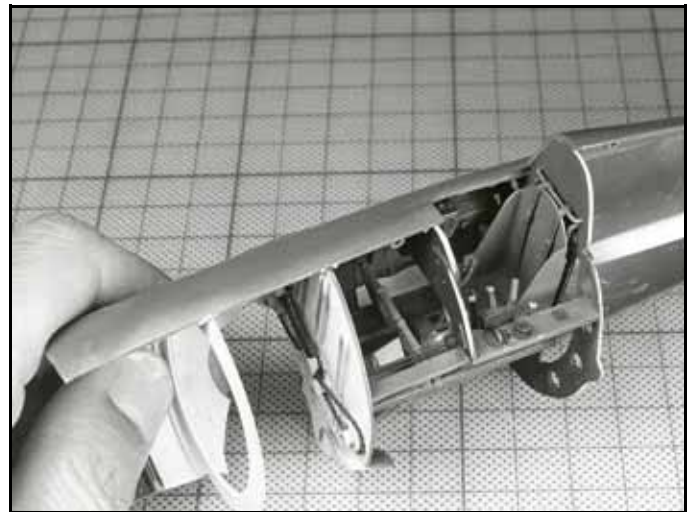

That's a pretty tight cockpit! The interior was painted various shades of green zinc chromate. The console, electrical boxes and adjustment dials were painted flat black with some flat white added.

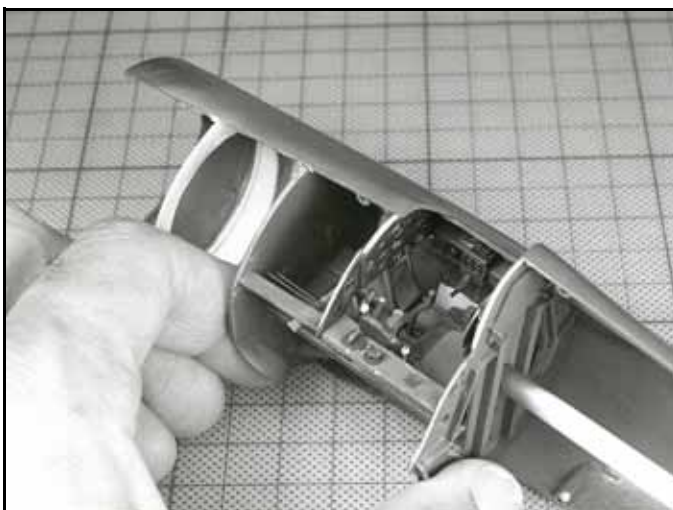

Note how all the parts fit together and have sharp demarcation lines between colors.



I may have made the engine controls a bit too big but in the pictures of Wildcat cockpits they appeared to be slightly oversized.



The chain drive for the landing gear was an HO scale chain from a model railroad detail set.

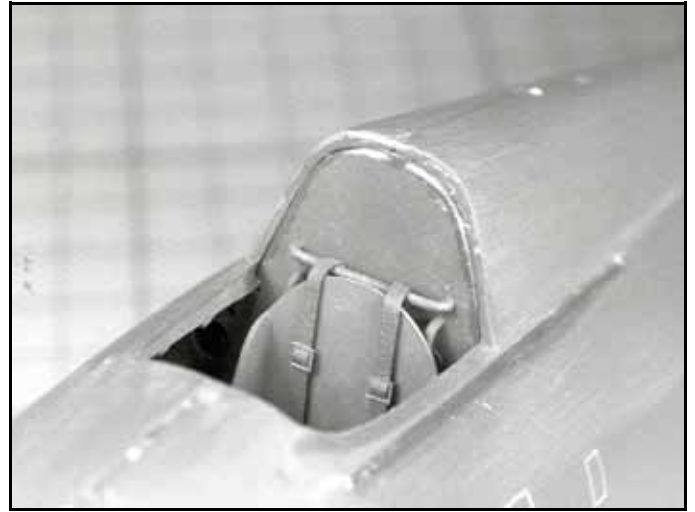

The top part of the rear cockpit wall needed some seam work. I applied small beads of super glue along the seam line.

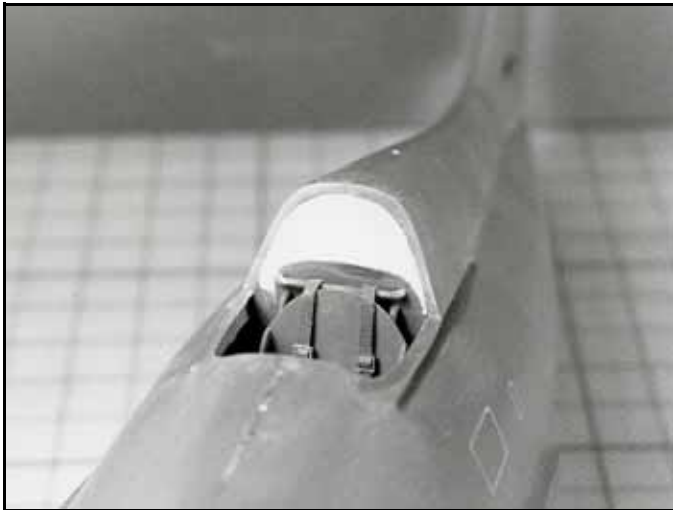

I carefully scraped the seam line flat with the tip of a number 11 X-Acto blade and then sanded the surface smooth with the tip of a sanding stick. The plastic was then polished with 0000 steel wool.

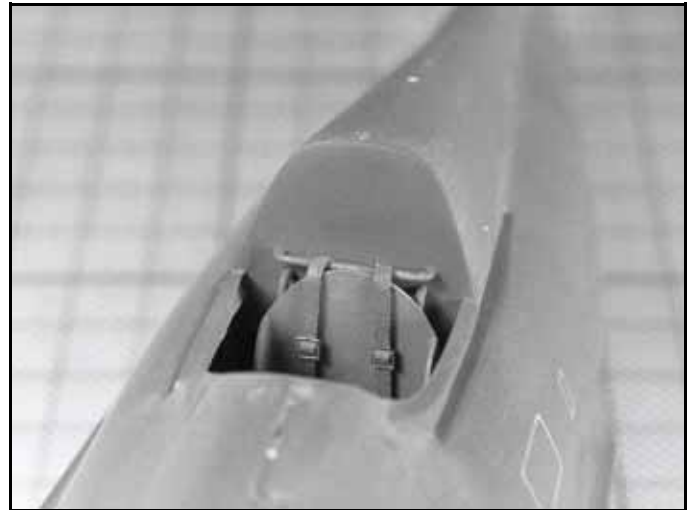

The area was primed and repainted and now its ready for the pilots head rest cushion.